

# FULLER-KINYON® TYPE N PUMP w/3 PC SCREW PARTS IDENTIFICATION

ITEM	REQ	DESCRIPTION
1	1	Hopper
2	1	Barrel
3	1	Dual Discharge Housing
4	1	Bearing Housing Support - Drive End
5	1	Bearing Housing - Drive End
6	1	Bearing Retainer - Drive End
7	1	Bearing Housing Support - Discharge End
8	1	Bearing Housing - Discharge End
9	1	Bearing Retainer - Discharge End
10	1	Base
11	1	Base Extension Plate
12	1	Discharge Body - Right Angle
13	1	Discharge Body - Parallel
14	1	Drive Shaft
14-1	1	Wear Sleeve
14-2	1	Keystock
14-3	1	Lock Washer
14-4	1	Lock Nut
15	1	Discharge Shaft
15-1	1	Wear Sleeve
15-2	1	Thrust Washer
15-3	1	Lock Washer
15-4	1	Lock Nut
16	1	Screw Bushing Assembly - Drive End
16-1	1	Wear Sleeve - 1
16-2	1	Wear Sleeve - 2
16-3	1	Lock Washer
16-4	1	Lock Nut
16-5	1	Screw Bushing Assembly - Discharge End
17	1	Wear Sleeve
18	2	Hopper Cover
19	2	Hopper Cover Gasket
20	1	Screw Assembly
21	2	Barrel Bushing
22	1	Barrel Bushing
23	1	Barrel Bushing
24	1	Hex.Nut
25	1	Inlet Trough
26	2	Bearing Sets
27	2	Bearing Housing Seal
28	1	Bearing Housing Seal
29	6	Seal Housing Seal
30	2	Grease Ring
31	2	Flapper Valve Assembly
32	2	Valve Seat Gasket
33	2	Blowout Lever
34	2	Set Screw Collar
35	2	Spacer Flange
36	2	Blowout Lever Shaft
37	2	Bearing Housing Support Guard

ITEM	REQ	DESCRIPTION
38	1	Plug, Square Head
39	2	Bolt ring
40	1	Bushing, Hex
41	1	Plug, Square Head
42	1	Tapered cap plug
43	1	Lubricating Fitting, Hydraulic, Straight
44	1	Shim
45	1	Lubricating Grease Fitting
46	1	Set Screw
47	4	Screw, Hex Head Cap
48	4	Washer
49	1	Socket Head Set Screw Cone Point
50	1	Stud
51	1	Nut
52	1	Washer
53	1	Hexagon Head Screw
54	1	Nut
55	1	Screw, Cap, Hex Head
56	1	Screw
57	1	Spring Washer
58	1	Stud
59	1	Screw
60	1	Spring Washer
61	1	Hexagon Head Bolt
62	1	Nut
63	1	Screw
64	1	Spring Washer
65	8	Spring Washer
66	8	Bolt
67	2	Torque hex. Flange Nut
68	2	Key

ITEM	REQ	DESCRIPTION
69	2	Key
70	1	O-Ring
71	1	O-Ring
72	4	O-Ring Viton
73	2	Air Filter / Regulator
74	2	Relief Valve
75	1	High Pressure Hose
76	1	Pressure Relief valve
77	2	Actuator mounting Bracket
78	1	Microalserter Filter
79	2	Support Bracket
80	1	Prefilter
81	2	Regulator mounting bracket
82	2	Filter Regulator w/Gauge
83	4	Tank
84	2	Choke Plug

ITEM	REQ	DESCRIPTION
85	1	Check Valve
86	1	2-Way Solenoid Valve
87	1	Pressure Switch
88	4	Pressure Gauge
89	1	Mounting Bracket
90	8	U-Bolt Assembly
91	1	Choke Plug
92	2	Actuator Rotary Pneumatic
93	2	Coupling, Flexible Jaw
94	4	Hose Assembly
95	4	Threaded Rod
96	2	Ball Valve
97	1	Spring washer
98	1	Hexagon head bolt
99	1	Nut

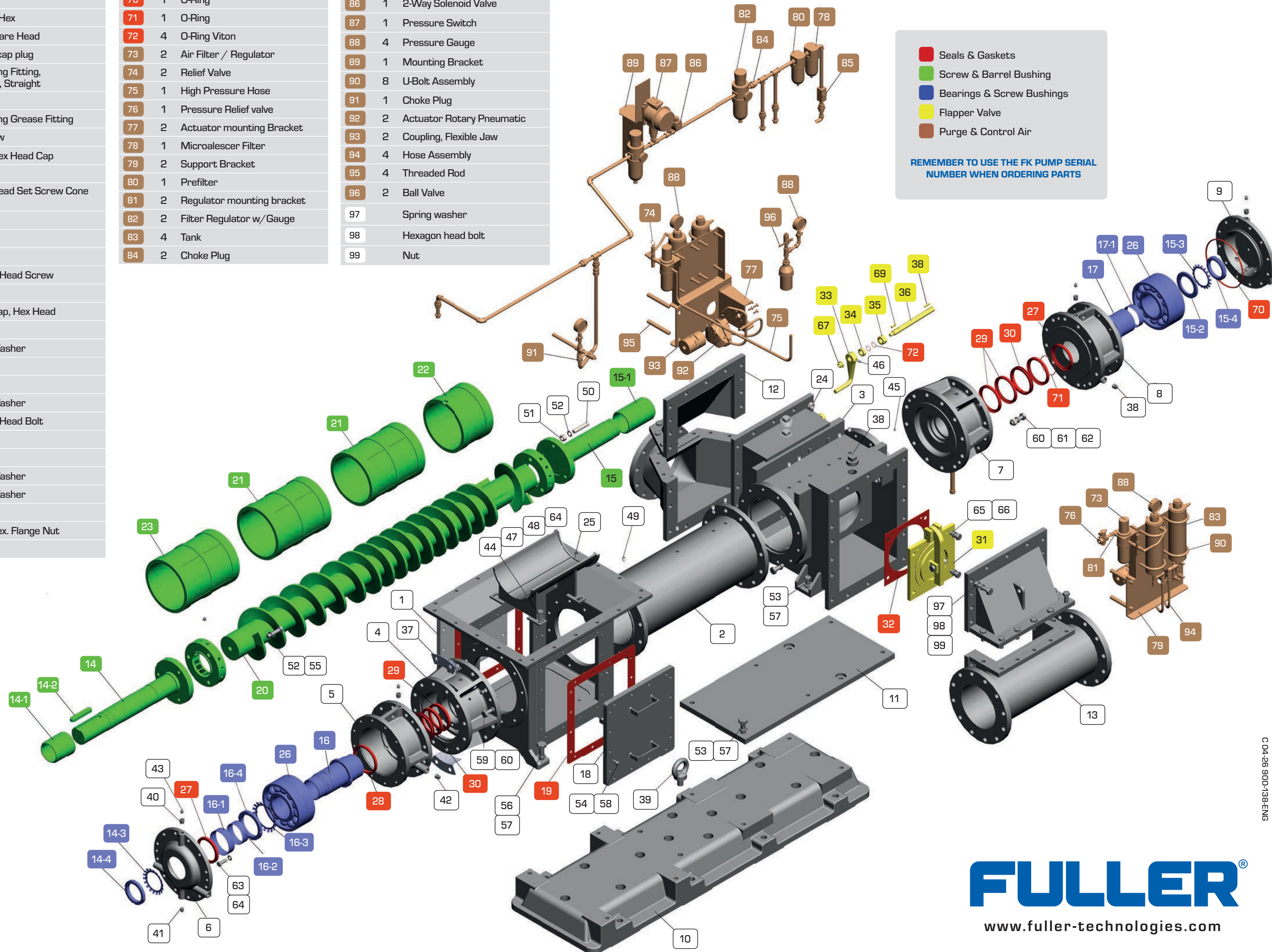

**FULLER-KINYON®**

# TYPE N PUMP w/3 PC SCREW “HOT SWAP” BEARING ASSEMBLIES

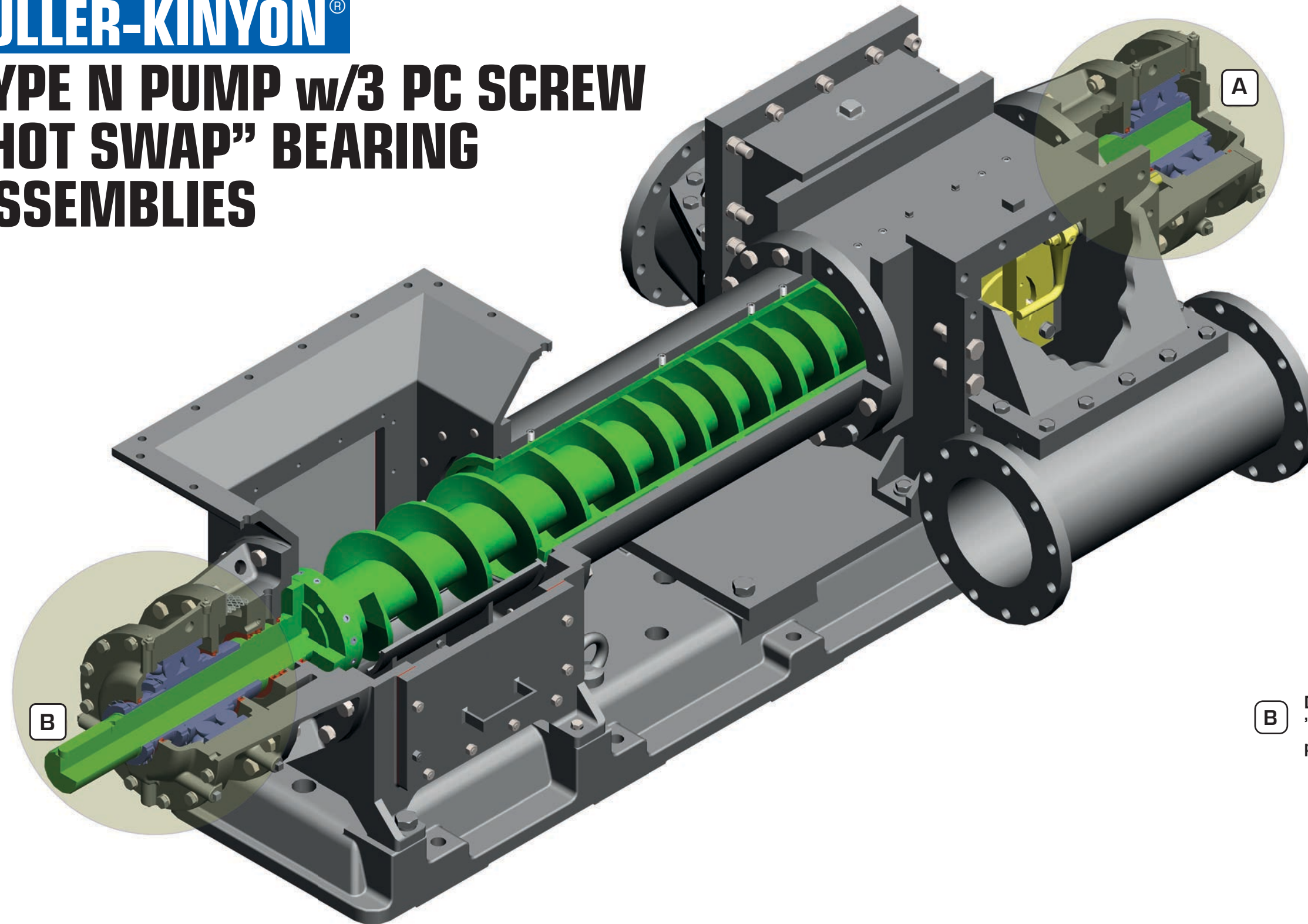

**A** Discharge end bearing housing,  
“Hot Swap” available  
pre-assembled

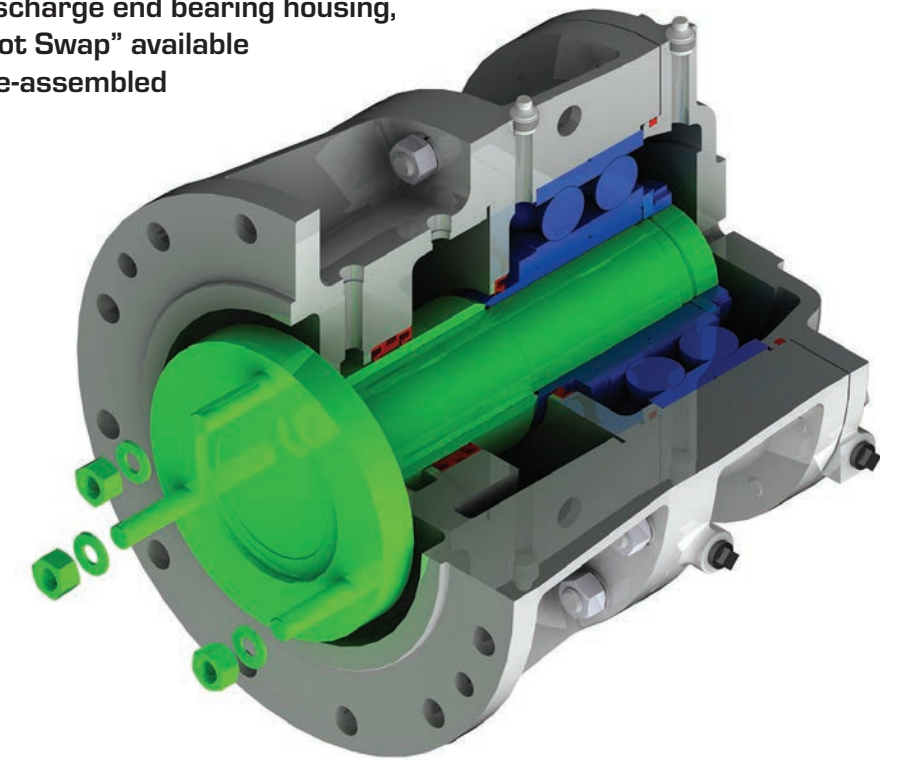

**B** Drive end bearing housing  
“Hot Swap” available  
pre-assembled

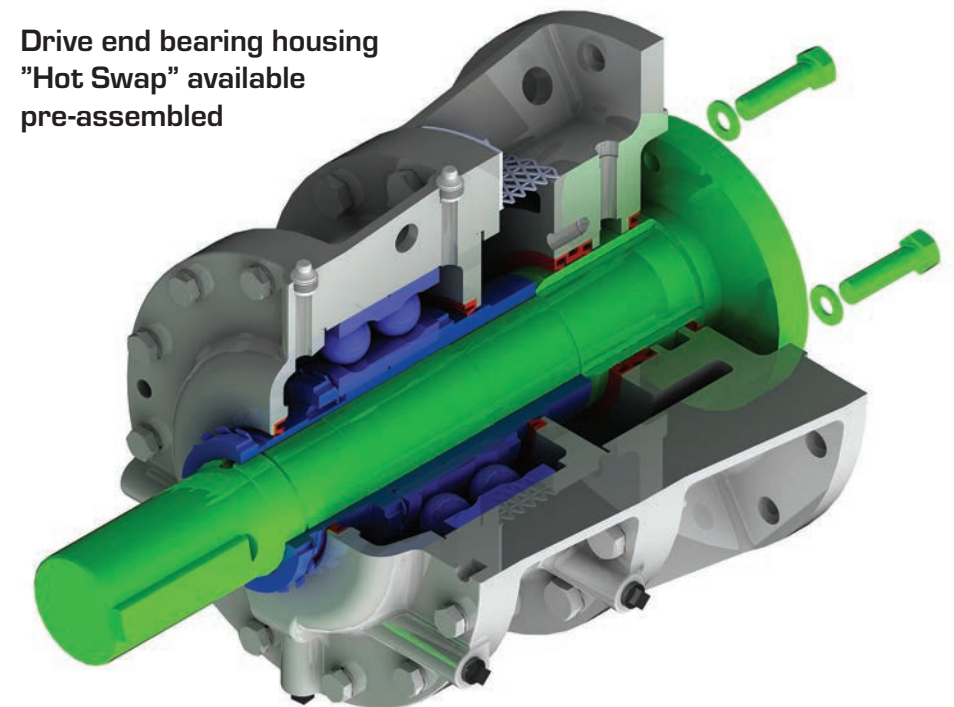

## FULLER-KINYON® PUMP 3-PIECE BEARING HOUSING EXCHANGE PROGRAM - “HOT SWAPS”

The “Hot Swap” is a fully-assembled FK Pump bearing housing for the 3-piece screw design. It comes installed with new seals, bushings, bearings, and is pre-lubricated.

Similar to Fuller’s compressor exchange program, the Hot Swap program exchanges worn 3-piece N pump bearing housing assemblies for new, warranted replacements. Ship your worn bearing assembly to one of our Service Centers. If an inspection reveals that its shaft, bearing housing, bearing support, and cover plate can be used again (many can be) for a future rebuild, there will be no upcharge for the good parts.

Quick delivery can also be made because large inventories of bearing housings maintained at Fuller’s Northampton plant and at our Certified Service Centers strategically located throughout the USA and Canada.

The cost of each hot swap is significantly less than buying the individual parts. The savings get even better when you factor in the reduced overall system downtime.

The cost of each hot swap is significantly less than buying the individual parts. The savings get even better when you factor in the reduced overall system downtime.

Maximize the benefits of the 3-piece screw in your Type N Fuller-Kinyon pumps by keeping Hot Swap bearing assemblies in your inventory. Having complete bearing assemblies readily available allows for immediate replacement and shortest possible downtime for your Fuller-Kinyon pump systems.

FOR MORE INFORMATION CALL US AT 610-264-6800,  
OR TOLL-FREE AT 800-795-6825.

**FULLER®**

[www.fuller-technologies.com](http://www.fuller-technologies.com)