

FULLER TECHNOLOGIES

EQUIPMENT & SERVICES



+++ LINE CARD +++

+++ LINE CARD +++

+++ LINE CARD +++

1ST MAR 2026

PRODUCTS SERVICES

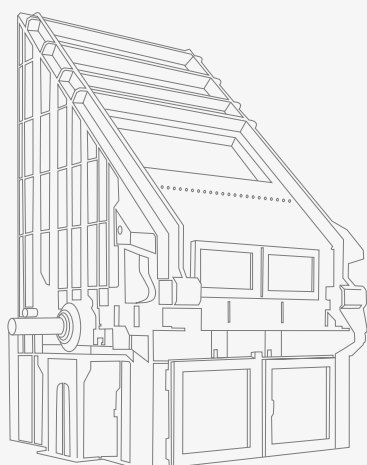

- PFISTER® TRW
- PFISTER® TRW-K
- PFISTER® URW
- PFISTER® SCF

PFISTER® Scales

- PFISTER® BS - Belt Scale
- PFISTER® SFM - Solid Flow Meter

PFISTER® weighfeeders

- PFISTER® SLF - Smart Linear Feeder
- PFISTER® Apron Weighfeeders

CRUSHING

Impact crushers

- Dryer crusher
- EV Hammer Impact Crusher
- Strike-Bar™ Crusher

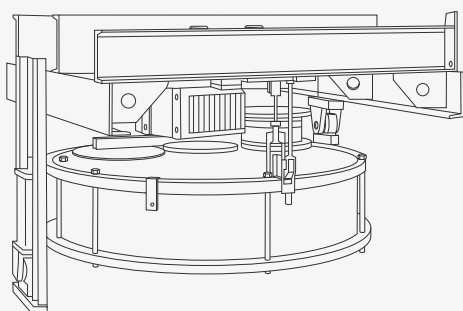

FEEDING AND DOSING

PFISTER® Alternative fuels solutions

- Feedex™ Overhead Reclaimer
- PFISTER® AF Starter Kit
- PFISTER® TRW-S/D

PFISTER® Rotor weighfeeders

- PFISTER® DRW
- AutoGAP™ 2.1 for PFISTER® DRW
- Smart Aeration for PFISTER® DRW
- FEEDflex™ for PFISTER® DRW
- PFISTER® FRW
- PFISTER® TRW-S/D

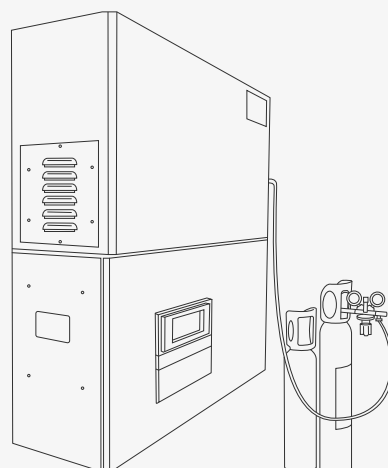

GAS ANALYSIS AND EMISSIONS MONITORING

Emissions monitoring

- Continuous Emissions Monitoring Systems (CEMS)
- Dust monitors
- Flow monitors

Gas analysis

- Double probe system for filter protection (DDOP)
- KilnLoq® Cold/Dry System for kiln inlet or calciner
- KilnLoq® HW Laser Gas Analysis System for kiln inlet or calciner
- Silo/Filter Probe System for coal mill

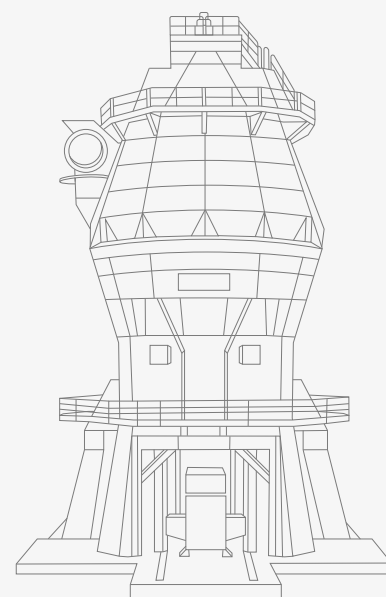

MILLING AND GRINDING

Ball mills

- Ball mills (TM, TMS, TUM, TUMS, Tirax)
- Cement powder cooler
- Gear Pinions
- Girth Gear
- O-SEPA™ Separator
- RTKM Separator
- SEPAX™ Separator
- Ball mill liners
- STANEX Diaphragm for Ball Mills

PRODUCTS SERVICES

Roller presses

- Hydraulic Roller Press
- Tribomax® Wear Surface

Vertical roller mills

- FRM Coal Mill
- ATOX® Coal Mill
- Hi-Chrome Wear Segments
- OK™ Cement Mill
- Rotary feeder airlocks
- OK™ Pro+ Ceramic Wear Segments
- FRM Raw Mill
- OK™ Raw Mill
- RAKM Separator
- ROKS/ ROKSH Separator

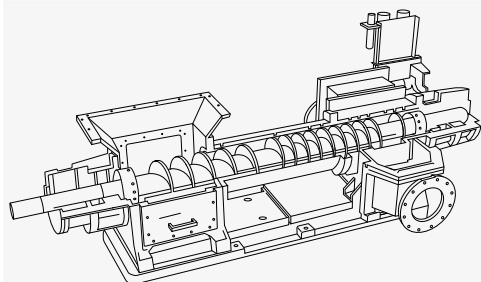

PNEUMATIC CONVEYING

Pneumatic Conveying Accessories

- Abrasion-resistant pipeline fittings

Pneumatic Conveying Feeders and Valves

- Flow control and shut-off valves
- Pneumatic Blending Systems
- Pressure tank systems
- Rotary valves for pneumatic conveying
- Storage and blending silos
- Two-way diverter valves for pneumatic conveying
- V-Series pneumatic feeder / airlock

Pneumatic Conveying Systems

- Airlift™ vertical conveying
- Airslide® Gravity Conveyors

Pumps and Compressors

- B3000™ V2 Compressor blades
- Fuller-Kinyon® (FK) screw pump
- Ful-Lube™ lubrication systems
- Ful-Vane™ Rotary Vane Air Compressor
- Ful-Vane™ Rotary Vane Gas Compressor

Ship unloaders and terminals

- Docksider® Ship and barge unloaders
- Ful-Floor™ Pneumatic Reclaim System
- KOVAKO® Ship and barge unloaders

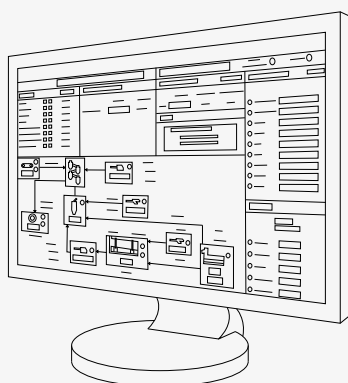

PROCESS CONTROL AND OPTIMIZATION

Process and machine control

- ECS/ControlCenter™ Process Control Solution

Process data management and insights

- ECS/UptimeGo (Downtime analysis software)
- ECS/PlantDataManagement
- SiteConnect Mobile Insights App

Process measurement and monitoring

- ECS/CemScanner™ Kiln Shell Monitoring System

Process optimisation

- ECS/ProcessExpert® Advanced Process Control Software (PXP)

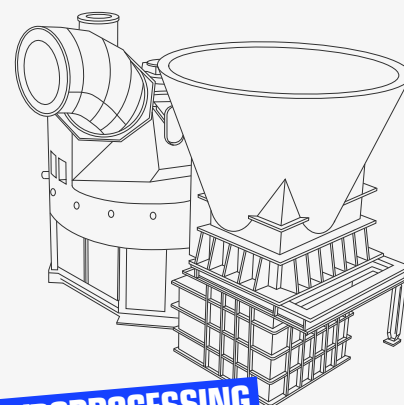

PYROPROCESSING

Coolers

- ABC™ Cooler Inlet
- SF™ Cooler
- Multi-Movable Cross-bar cooler (MMC)
- Coolax
- CFG Cooler
- Cross-Bar® Cooler
- Heavy-duty Roll Breaker (HRB)
- Wave grate for SF™ and Multi-Movable coolers
- Clinker hammer crusher

Firing systems

- FUELFLEX® Pyrolyzer
- HOTDISC® Reactor
- Duoflex® Kiln burner
- JETFLEX® 2.0 Kiln burner
- Satellite burner
- Hot Gas Generator (HGG)

PRODUCTS SERVICES

Kilns

- 3-Base Kiln
- Gear Pinions
- Girth Gear
- Kiln Graphite Seal
- Precast Kiln Outlet Sectors
- ROTAX-2® Rotary Kiln
- HTD (hydraulic thrust device) for kilns
- Lamella and pneumatic kiln seals
- Spring-tensioned Kiln Graphite Seal

Preheaters

- Cast central pipe for high-temperature cyclones (thimble)
- In-Line Calciner Preheater System (ILC)
- Low NOx Calciner
- TA (tertiary air) damper
- Bypass systems
- Clay calciner
- Sluice flaps
- Expansion joints

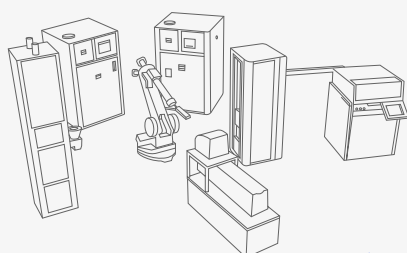

SAMPLING, PREPARATION AND ANALYSIS

Automated laboratories

QCX/RoboLab® Systems

Laboratory software and quality optimisation

QCX® Advanced Quality Control Systems (QCX/BlendExpert™)

QCX® Laboratory software

Sample analysis

- QCX® Automatic Blaine Analyser
- QCX® Carbon Sulphur Analyser
- QCX® CUBE X10 Online Elemental Analyser
- QCX® CUBE X20 Online Free Lime Analyser

Sample preparation

- QCX® Automated Soft Press for XRD sample preparation
- QCX® Centaurus® Combined Mill and Press
- QCX® Dosing, Cleaning and Fusing Units
- QCX® X-ray manual sample mill
- QCX® X-ray manual sample press

Sampling and sample transport

- QCX® Automated Samplers
- QCX® AutoSampling Systems

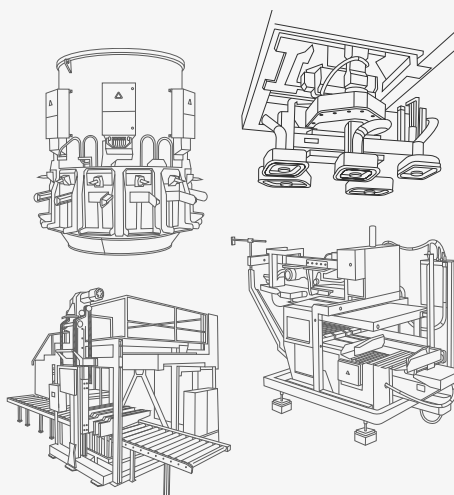

STORAGE AND DISPATCH

VENTOMATIC® Silos

- CF Silo for raw meal
- CFI cement storage silo
- CFMI silo for multiple products
- CFS cement storage silo

MDS Silo for long term storage

Storage and blending silos

VENTOMATIC® Empty bag handling and storage

- VENTOFEED™ SR Empty Bag De-palletiser
- INFILROT™ Automatic Bag Applicator for rotary packers

VENTOMATIC® Filling units

- BIG BAG Filling Systems
- FILLPro™ dust reduction kit
- GIROMAT™ EVO rotary packers
- GIROMAT™ rotary bag packers
- VENTOSEAL™ CL Ultrasonic Valve Bag Sealing System

VENTOMATIC® Palletising

- POLIMAT® Palletisers
- FFL™ Automatic Loader for open-top trucks
- FFL™-4C Automatic Loader for closed truck and containers

VENTOMATIC® Truck and wagon loading

- CARICAMAT® Automatic Truck Loaders
- Upgrades for CARICAMAT® Automatic Truck Loader
- CARICATECH™ Automatic Truck Loaders

PRODUCTS SERVICES



ADVANCED SERVICES

- Technical management
- Installation services
- Material testing services
- Training and development
- Bulk Material Test Laboratory
- Reliability Centered Maintenance (RCM)
- ATOX[®] Mills - Online Reliability Services
- OK[™] Mills - Online Reliability Services
- Kilns - Online Reliability Services
- Cross-Bar[®] Cooler - Online Reliability Services



MAINTENANCE

- Crusher maintenance services
- Rotor retrofit for limestone crusher
- PFISTER[®] feeding and dosing services
- Gas analysis services and upgrades
- Gear services
- Maintenance Service Agreements

- PlantLine[™] Agreement
- Ful-Vane[™] Compressor exchange program
- Hard facing services for VRMs
- Line boring services
- Kiln resurfacing
- White metal bearings refurbishment
- Roller rebuild service for OK, ATOX and FRM Mills
- Vertical roller mill services
- SiloSafe Cement service
- Fluxo[™] pump retrofit
- Pneumatic Conveying services
- Cybersecurity assessments
- Cooler services
- Kiln services
- Comprehensive hot kiln alignment
- Packing and dispatching equipment services



OPTIMIZATION

- Mill start-up
- Carbon capture optimisation service
- Electrical and automation audits
- Calcined clay plants - service agreements
- Lab audits

Please note the following

This list of products and services is representative of our portfolio as of March 2026 and is intended to provide general guidance regarding the capabilities of Fuller Technologies. The list is not exhaustive of our complete Intellectual Property.

FULLER[®]

fuller-technologies.com



Copyright © 2026 FULLER Technologies. All Rights Reserved. FULLER[®] is a registered trademark of FULLER Technologies. This brochure makes no offers, representations or warranties (express or implied), and information and data contained in this brochure are for general reference only and may change at any time.

03-26 000-120-ENG